

REVISIONS				
ZONE	REV	DESCRIPTION	DATE	APPROVED
	1	Corrected mtg. dims. for mtg. bracket	3/23/06	

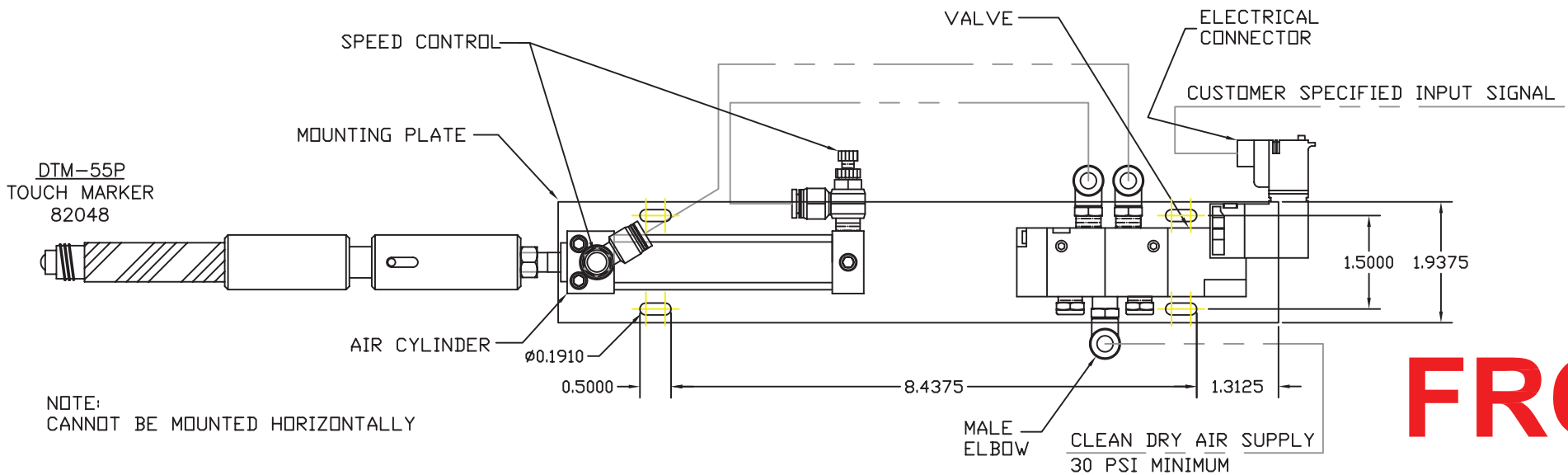

**FRO**

*	STANDARD INPUT SIGNAL	CN NUMBER
E3	24 VDC	83147
E6	110 VAC	83146

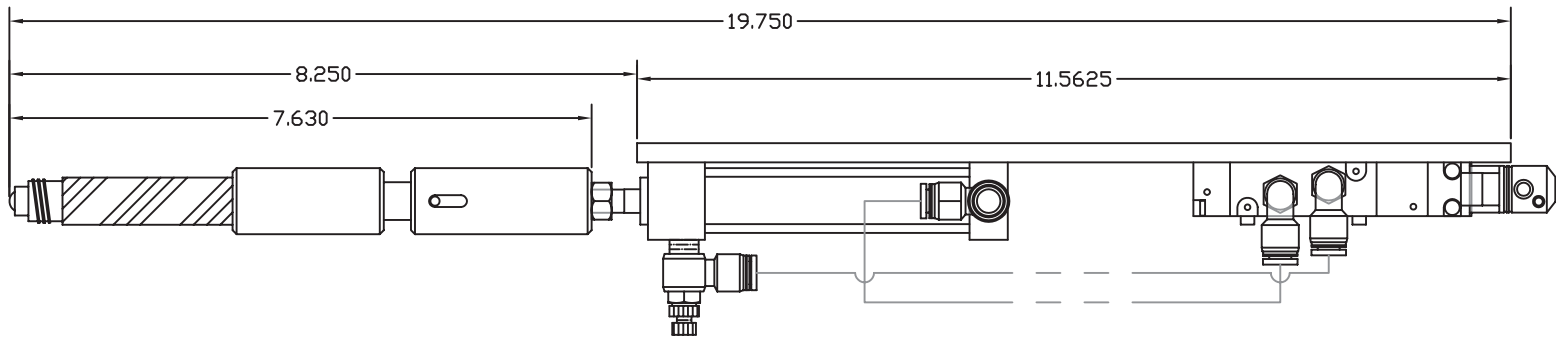
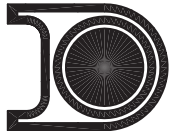

DELL MARKING SYSTEMS INC.  
721 WANDA  
FERNDALDE, MICHIGAN 48220

DESCRIPTION *DTMS-55P-3CYL-\*  
TOUCH MARKING SYSTEM*

*3" STROKE*

DATE *N/A* ID NUMBER

PART NUMBER *NOTED* SCALE *NONE*